



RANO-EVS-230T

Screening output	30 - 60 tons/hour	Double deck twin motor vibration screener.
Max bucket width	2300 mm	Screener suitable for loaders with bucket width up to 230 cm / volume up to 0,9 m ³ , and miniexcavators of total weight 5 to 8 tons.
Screening area	2 x 2,7 m ²	
Power input	400 V / 1,5 kW	Suitable with miniexcavators: KUBOTA KX - 060/085 U - 50/56, CAT 305/306/307.5/308, JCB 50Z/56Z/60C/85Z/86Z/90Z, BOBCAT E50z/E55z/E60/E85/E88, KOMATSU PC 55/58/80/88, WACKER NEUSON ET42/ET58/ET65/EZ50/EZ80, YANMAR SV60/B75W/ViO50/ViO57/ViO80/B7, VOLVO ECR50/58/EC60
Weight	1400 kg	
Width (A)	2550 mm	
Length (B)	1470 mm	
Height (C)	2340 mm	

Suitable with loaders: AVANT 800, MULTIONE 11 SERIES, WACKER NEUSON WL 34/44, BOBCAT L75/L85/S76/S86/T66/T76/T86, MECALAC AX 700/850/AS600/AS750, JCB 2CX COMPACT/406/250/270/300/330, KUBOTA R70/R90, CAT 906, CAT 272/279/289/299, LIEBHERR L504/L506, KOMATSU WA 70/80, TEREX TL 65/70S/80, YANMAR V7/70S/80, WEIDEMANN 3080/4080, GIANT 5000, KRAMER 5065/5075/5085/8085, WEYCOR AR 400/420

- Optional Attachments**
- Conveyor belts in lengths of 3, 4, 5 and 6 meters
 - Sorters and divider
 - Other types of the sieves

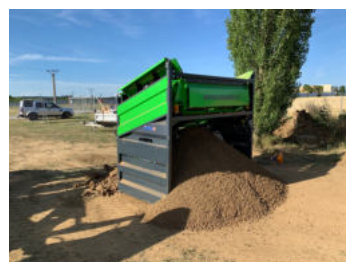
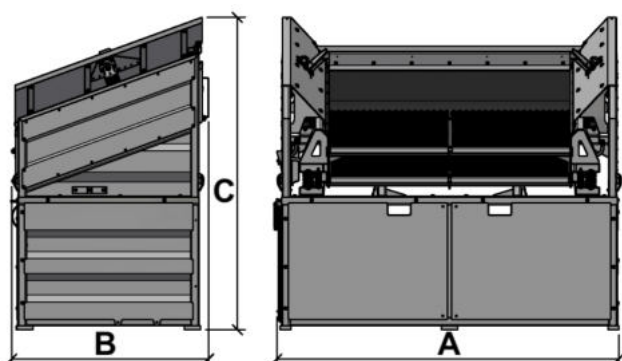

Producer reserves all rights to change technical specification of the screeners without prior notice. Please, contact us at all times for exact technical details, such as transport dims and weights.